

OPERATING, INSTALLATION AND SERVICE MANUAL FOR INSTALLATION IN RECREATIONAL VEHICLES AND MOBILE HOUSING

GAS HOT WATER STORAGE HEATER MODELS SW4DA • SW6DA • SW4DEA • SW6DEA



MANUFACTURED BY AIRXCEL, INC. - SUBURBAN DIVISION

FOR YOUR SAFETY

WHAT DO YOU DO IF YOU SMELL GAS?

- DO NOT TRY TO LIGHT ANY APPLIANCE.
- DO NOT TOUCH ANY ELECTRICAL SWITCH.
- DO NOT USE ANY PHONE IN YOUR BUILDING OR RV.
- IMMEDIATELY CALL YOUR GAS SUPPLIER FROM A NEIGHBORS' PHONE & FOLLOW THEIR INSTRUCTIONS.

FREEZE WARNING

DRAIN HEATER IF SUBJECTED TO FREEZING TEMPERATURES

WARNING: IMPROPER INSTALLATION, ADJUSTMENT, ALTERATION, SERVICE OR MAINTENANCE CAN CAUSE INJURY OR PROPERTY DAMAGE. REFER TO THIS MANUAL FOR ASSISTANCE OR FOR ADDITIONAL INFORMATION CONSULT AN AUTHORISED INSTALLER, SERVICE AGENCY OR GAS SUPPLIER.

ADDITIONAL SAFETY

DO NOT STORE OR USE PETROL, OR OTHER COMBUSTIBLE MATERIALS OR LIQUIDS NEAR OR ADJACENT TO THIS HEATER OR ANY OTHER APPLIANCE. THIS APPLIANCE SHALL NOT BE INSTALLED IN ANY OTHER LOCATION WHERE FLAMMABLE LIQUIDS OR VAPORS ARE LIKELY TO BE PRESENT. WARNING! THIS APPLIANCE IS UNSUITABLE FOR USE AS A POOL HEATER.

THIS APPLIANCE IS NOT INTENDED FOR USE BY YOUNG CHILDREN OR INFIRM PERSONS WITHOUT SUPERVISION. YOUNG CHILDREN SHOULD BE SUPERVISED TO ENSURE THAT THEY DO NOT PLAY WITH THE APPLIANCE.

INSTALLER: AFFIX THESE INSTRUCTIONS TO OR ADJACENT TO THE WATER HEATER.

OWNER: RETAIN THESE INSTRUCTIONS AND WARRANTY FOR FUTURE REFERENCE.

ALL TECHNICAL AND WARRANTY QUESTIONS SHOULD BE DIRECTED TO THE COMPANY LISTED ON THE WARRANTY, OR RATING PLATE WHICH CAME WITH YOUR HOT WATER HEATER.

**Gas appliance repair is not a do it yourself type of repair.
All repairs should be performed by a qualified service agency.**

SPECIFICATIONS AND DATA FOR SUBURBAN STORAGE HOT WATER HEATER

(SW4DEA)

(SW6DEA)

(SW4DA)

(SW6DA)

1. Specifications:				
Capacity:	15.1 Liters	22.6 Liters	15.1 Liters	22.6 Liters
Maximum Working Pressure:	850 kPa	850 kPa	850 kPa	850 kPa
Hourly Gas Consumption:	9.6 MJ per Hour	9.6 MJ per Hour	9.6 MJ per Hour	9.6 MJ per Hour
Test Point Pressure:	2.63 kPa	2.63 kPa	2.63 kPa	2.63 kPa
Inlet Pressure	2.75 kPa	2.75 kPa	2.75 kPa	2.75 kPa
Inlet Pressure New Zealand	2.5 - 3.5 kPa	2.5 - 3.5 kPa	2.5 - 3.5 kPa	2.5 - 3.5 kPa
Jet Orifice Size:	.89mm	.89mm	.89 mm	.89 mm
Type of Gas:	Universal LPG	Universal LPG	Universal LPG	Universal LPG
Recovery:	40 L/hr 45°C rise	40 L/hr 45°C rise	40 L/hr 45°C rise	40 L/hr 45°C rise
Electrical:				
a. For Automatic Gas Ignitor	12 Volt D.C.	12 Volt D.C.	12 Volt D.C.	12 Volt D.C.
b. For Models with 240 Volt Heating Element	240 Volt 50 HZ.A.C. 1440 Watts 6 Amp	240 Volt 50 HZ.A.C. 1440 Watts 6 Amp	N/A	N/a
2. Width:	320mm	320mm	320mm	320mm
Height:	320mm	320mm	320mm	320mm
Depth:	450mm	500mm	450mm	500mm
3.	Location of hot water inlet is 70mm from top dead center. Location of cold water inlet is 55mm from bottom dead center. Location of flue outlet is 95mm from RH top edge of unit. Location of gas inlet connection point is 40mm from the left hand edge of the control housing.			
4. Size of inlet 3/8"	DO NOT place articles on or against this appliance. DO NOT use or store flammable materials near this appliance.			

INSTALLATION REQUIREMENTS

WARNING! Installation of this appliance must be made in accordance with the written instructions provided in this manual. No agent, representative or employee of Suburban or other person has the authority to change, modify or waive any provision of the instructions contained in this manual.

NOTE: Do not install the water heater with the door facing toward the forward end of the coach. See Figures 10, 11 and 12.

CAUTION: If possible, do not install the water heater to where the vent can be covered or obstructed when any door on the trailer is opened. If this is not possible, then the travel of the door must be restricted in order to provide a 6" minimum clearance between the water heater vent and any door whenever the door is opened.

CAUTION: Due to the differences in vinyl siding, this appliance should not be installed on vinyl siding without first consulting with the manufacturer of the siding or cutting the siding away from the area around the appliance vent.

CAUTION: In any installation in which the vent of this appliance can be covered due to the construction of the RV or some special feature of the RV such as slide out, pop-up etc., always insure that the appliance cannot be operated by setting the thermostat to the positive "OFF" position and shutting off all electrical and gas supply to the appliance.

CAUTION: Do not install this appliance to where the vent terminates below a slide-out. This appliance is not to be installed under any overhang. It must be free and clear of any type overhang.

This appliance shall be installed only by authorised persons and in accordance with the manufacturer's installation instructions, local gas fitting regulations, electrical wiring regulations, local water supply regulations, AS/NZS 5601.2; gas installations and any other statutory regulations. Installation shall be in accordance with AS/NZS 3500.4.

1. The appliance shall be disconnected from the gas supply piping system during any pressure testing of the system.
2. The appliance and its gas connections shall be leak tested before placing the appliance in operation.
3. All air for combustion must be supplied from outside the structure. Air for combustion must not be supplied from occupied spaces.
4. This unit is a balance flue heater.
5. Discharge pipe must be mounted at the pressure relief valve and installed through floor line of caravan or motor home, and must be left open to free air so as water can escape if required and is to be installed in a continuously downward direction and in a frost-free environment. For convenience, a break-thru grommet has been provided in the bottom of the control housing. The center of the grommet may be pierced and piping routed through.
6. A mains pressure reducing valve must be installed in the incoming water line with a rating of 350 kPa (50 psi). Please Note: Warranty will be void if pressure reducing valve is not installed.

INSTALLATION INSTRUCTIONS

Keep the heater and flueway at least 25mm clear of anything that is combustible, like walls, cupboards and timber.

Provide an opening flush with floor in outer wall of coach as shown. Wall of coach should be framed as shown in Figure 1. Maintain inside dimensions listed below. Do not install on carpet unless the carpet is covered by a metal shield at least 50mm greater than the width of the water heater.

INSTALLATION USING HINGED DOOR

(See Figure 2 for models SW4DEA/SW6DEA) (See Figure 2A for models SW4DA/SW6DA)

- A. In some limited accessibility applications, the chocks as illustrated in Figure 1A must be installed prior to setting water heater into position. Install chocks, one on each side of water heater, as illustrated in Figure 1A.
- B. Position heater into framed opening as illustrated.
- C. On mesa or yoder type sidewalls, flatten the wall area around the opening.
- D. Caulk around framed opening (trailer skin) as illustrated.
- E. Lay a bead of silicone caulking (or suitable caulking) around the inner edge of the control housing (top, bottom and sides). See detail "A" in illustration. This will seal frame to control housing.
- F. Apply a bead of silicone caulking (or suitable caulking) around back side of door frame. See detail "A" in illustration. This will seal frame to coach skin.
- G. Fit the door frame into control housing (over the caulking already applied) and pull frame tight to control housing using the three (3) No. 8-15 x 3 1/2" screws provided.
- H. Push water heater into framed opening until back side of door frame (now attached to control housing) is against the side of the coach and firmly attach with screws around the perimeter of the frame. NOTE: The two (2) holes in bottom of frame identified as "A" in Figure 2 are also used to mount door hinge to the frame.
- I. If already installed, confirm chocks are supporting the water heater correctly. If not already completed, install chocks, one on each side of water heater, as illustrated in Figure 1A.
- J. Attach door to frame as illustrated.
- K. Close the door so that the door latch protrudes through the slot in the door. Turn latch 90 degrees to fasten door. Be sure the extension on the flue protrudes through the door a minimum of 15 mm.
- L. The module board is not secured to the water heater. It is to be permanently mounted by the installer.

The module board must be mounted to where it is accessible for service yet out of way of children. It should be located in a place where it cannot be subjected to moisture, cleaning chemicals, flammable vapors and liquids, etc. The board and all wiring to the board must be protected in order to prevent damages and accidental contact with these parts. The module board may be mounted with two (2) No. 6 x 5/8 screws or other suitable hardware.

MAKING WATER CONNECTIONS

WARNING! A tempering valve or other similar device must be installed between the outlet of the hot water service and any faucet.

Connect water lines to rear of unit. Suitable fittings must be used in rear of hot and cold water connections. **DO NOT** glue metal fittings. This will void warranty.

NOTE: Inside each fitting is a suitable fill tube installed by manufacturer. Its purpose is to enhance water circulation. **DO NOT REMOVE THE PLASTIC FILL TUBES.**

Fill tank with water. Always open both the cold and hot water taps when filling vehicle water tank to allow air pockets to be forced out of the water heater. When tank is filled, turn off taps and check for leaks at connections. After leak testing, drain water from tank.

MAKING GAS CONNECTIONS

Connect 3/8" flare fitting gas supply to gas connection located in the control housing. When making the gas connection, hold the gas fitting on the valve with a wrench when tightening the flare nut. Failure to hold fitting secure could result in a gas leak due to fitting being damaged. **NOTE:** It will be necessary to remove the grommet from the control housing, make the gas connection at the valve, then reinstall grommet. Refer to AS5601 for gas pipe size.

WARNING! It is imperative that grommet and gas line through grommet be caulked air tight. If not tightly sealed, moisture and potential harmful flue products could vent through opening and into living area of trailer. (See Figure 4.)

Before leaving: check all connections for gas leaks with soap and water. Do not use a naked flame for detecting leaks. Ignite burner to ensure correct operation of gas valve, burner and ignition. Observe stability of the flame. When satisfied with the heater, please instruct the user on the correct method of operation. In case the appliance fails to operate correctly after all checks have been carried out, refer to the authorised service provider in your area.

MAKING ELECTRICAL CONNECTIONS

12 VOLTS D.C. (For All Models)

- Refer to Figure 2 for location of D.C. junction box.
 - The electrical connection must be made to conform with the local authority having jurisdiction or in the absence of such requirement with the latest Australian electrical code.
 - Make the 12 Volt D.C. electrical connections following the wiring diagram illustrated in Figure 5.
- We recommend insulated terminals be used on all electrical connections.

MAKING ELECTRICAL CONNECTIONS

240 VOLTS A.C. (For Models SW4DEA and SW6DEA only)

- Refer to Figure 2 for location of A.C. Junction box.
- The electrical connection must be made to conform with the local authority having jurisdiction or in the absence of such requirement with the latest Australian electrical code. All electrical work to be conducted by a licensed electrician.
- Check rating plate and wiring diagram (Figure 5A) before proceeding. Install a fused safety switch or circuit breaker of adequate capacity between heater and electrical power source. Attach the active and neutral wires from the fused switch or breaker to corresponding terminals in heater junction box. An earth wire from a well grounded source must be attached to the earth terminal in the junction box.

CAUTION: Before applying the 240 VAC power to the water heater junction box, be sure the switch for electric element is in the "OFF" position.

WARNING! Before the switch for the electric element is turned to the "ON" position, the water heater tank must be filled with water. See "SAFETY WARNINGS"

MAINTENANCE

WARNING! If the user of this appliance fails to maintain it in the condition in which it was shipped from the factory or if the appliance is not used solely for its intended purpose or if appliance is not maintained in accordance with the instructions in this manual, then the risk of a fire and/or the production of carbon monoxide exists which can cause personal injury, property damage or loss of life.

WARNING! For your safety, all repairs should be performed by an authorised service person.

- Burner Adjustment - All air shutters are pre-set at the factory to obtain a blue or orange-blue flame. If necessary to adjust your air shutter, be sure to keep this color and do not allow the burner to burn yellow or sooting will occur.

In cases where sooting has occurred, there is a possibility that this condition may be corrected by making the correct air shutter adjustment. If the burner flame continues to burn yellow after air shutter has been adjusted, check for an obstruction in the burner or flue box. Also, check to be sure there is no flame present at burner orifice or burner whenever main gas valve is closed. This can be checked by turning the OFF/ON switch to the "OFF" position. A stiff brush is recommended for the removal of soot deposits.

- Frequent checks should be made of the grommet on the gas inlet to assure tight seal. (See "Making Gas Connections").
- Periodically check wiring and wire connection to be sure wiring is not damaged/frayed and that all terminals and connections are tight and in compliance with codes (See "Making Wire Connections").
- The following is information regarding Hot Water Services and corrosion of the tank in Australia. The single biggest factor is metal/water contact.
 - Mains Water Connection- For correct performance and warranty of the unit, when connected to mains water supply, pressure must be limited to approximately 350 kPa (50 PSI) by the use of a suitable pressure regulator. Failure to do so will void warranty.
 - A suitable 1/2" BSPT fitting must be used for coupling HWS to water supply.
 - Water supply is an overall factor.
 - Tanks should be drained and flushed regularly - how often depends on soluble/silt content in water. Outback areas will be more of a problem than major city supplies.
 - Do not use bore water. This will void your warranty as the salt contents of bore water are extremely high.
 - The life of the anodes, which are a low valve replacement part, varies with water quality. Anodes must be inspected periodically. Use only genuine Suburban anode rods. Use of other anodes may void the warranty. Please see Anode Protection Section.
 - Your water system should be operated periodically even though the van is not being used, at least twice per week.
 - Anodes must be checked every 6 (six) months. Please see Anode Protection Section.

SAFETY WARNINGS

WARNING! It is imperative that the water heater tank be filled with water before operating the water heater. Operation of the water heater without water in the tank may result in damage to the tank and/or controls. This type of damage is not covered by the limited warranty.

WARNING! Hydrogen gas may result if you have not used this heater for two weeks or more. HYDROGEN GAS IS EXTREMELY FLAMMABLE. To reduce the risk of injury under these conditions, open the hot water faucet for several minutes at the kitchen sink before you use any electrical appliance connected to the hot water system. If hydrogen is present, you probably will hear an unusual sound such as air escaping through the pipe as the water begins to flow.

Hydrogen gas may be present even after water has been drained from the tank. Open faucet at sink and allow system to vent for several minutes (5-10 minutes). Do not smoke or have any open flame near the open faucet. Do not attempt to light pilot or main burner. On DSI models, be sure the switch is "OFF".

Should overheating occur, or the gas supply fail to shut off, shut off the manual gas valve to the appliance before shutting off the electrical supply. Do not use this appliance if any part has been submerged under water. Immediately call an authorised service technician to inspect the appliance and to replace any part of the control system and any gas control that has been submerged under water

Do not alter the operation of your water heater nor change the design/construction of your water heater. Accessories are being marketed for RV products which we do not recommend. For your safety, only factory authorized parts are to be used on your water heater.

Periodically inspect the vent for obstructions or presence of soot. Soot is formed whenever combustion is incomplete. This is your visual warning that the water heater is operating in an unsafe manner. If soot is present, immediately shut the water heater down and contact your dealer or an authorised service person.

When considering add-on rooms, porch or patio, attention must be given to the venting of your water heater. For your safety, do not terminate the vent on your water heater inside add-on rooms, screen porch or onto patios. Doing so will result in products of combustion being vented into the rooms or occupied areas.

Never operate the heater if you smell gas. Do not assume that the smell of gas in your RV is normal. Any time you detect the odor of gas, it is to be considered life threatening and corrected immediately. Extinguish any open flames including cigarettes and evacuate all persons from the vehicle. Shut off gas supply at LP gas bottle. (See Safety notice on front cover of this manual.)

Pressure relief valve to be operated at least once every 6 months to remove lime deposits and verify it is not blocked. Failure to do so may result in heater exploding. Continuous leakage from valve may indicate a problem with unit.

NOTE: Always open both the cold and hot water faucets when filling vehicle water tank to allow air pockets to be forced out of the water heater. When water flows from the heater faucets, close both faucets.

WARNING! Do not store or use combustible materials or liquids near or adjacent to this heater. The appliance shall not be installed in any location where flammable liquids or vapors are likely to be present.

Be sure the power is "OFF" to the water heater ignition system during any type of refueling and while vehicle is in motion or being towed.

WARNING! The thermostat on your water heater is not adjustable. It is a temperature sensing limit designed to maintain a temperature of 60°C to comply with AS/NZS 3500 Part 4.2. Water temperatures over 60°C can cause severe burns instantly or death from scalds; therefore, be careful when using hot water. Children, disabled and elderly are at highest risk of being scalded. Always feel water before bathing or showering. Children or infirm persons must not adjust, light, or operate any electrical or gas controls on this unit.

THERMOSTAT AND MANUAL RESET

For all Models

The model water heaters listed above are equipped with a high temperature limit as a cut-off device. Temperature above 82°C will cause manual reset button to trip shutting down main burner.

To activate burner, the water temperature must be below 37°C. Push reset button to re-activate burner.

THERMOSTAT AND MANUAL RESET

For Models SW4DEA and SW6DEA

The model water heaters listed above are equipped with a high temperature limit as a cut-off device. Temperature above 82°C will cause manual reset button to trip shutting down the electric element.

To activate element, the water temperature must be below 37°C. Push reset button to re-activate the electric element.

ANODE PROTECTION

The tank in this water heater is protected by a magnesium or aluminum anode to prolong the life of the tank. Removal of the anode will decrease tank life and will void the warranty on the inner tank. Anode must be checked every 6 (six) months, and replaced if below 50% of original diameter, failure to do so will void your warranty. Use only genuine Suburban anode rods. Use of other anodes may void the warranty. Anode performance depends on water quality, therefore are **NOT** covered by warranty.

To prevent a water leak when replacing the anode rod, a pipe thread sealant approved for potable water (such as Teflon Tape) must be applied to the threads of the anode rod. Proper application of a thread sealant will not interfere with the anode's tank protection.

Anode Dimensions: Length - 215mm, Diameter - 17mm.

NOTE: Tank is drained by removing anode rod (See "Drain and Storage" instructions).

To extend anode life, drain water from tank whenever RV is not being used. Avoid any extended time of non-use with water in tank. Also, refer to the section on winterizing.

WARNING! Do not replace the anode rod with any non-Suburban accessory part, such as an "add-on" electric heating element. Items such as these are not approved to be installed in Suburban products. They could create an unsafe condition and will also void all warranties.

PRESSURE RELIEF VALVE

The temperature and pressure relief valve is designed to open if the temperature of the water within the heater reaches 98.9 degrees Celsius, or if the water pressure in the heater reaches 850 kPa. Recreational vehicle water systems are closed systems and during the water heating cycle the pressure build-up in the water system will reach 850 kPa. When this pressure is reached, the pressure relief valve will open and water will drip from the valve. This dripping will continue until the pressure is reduced to below 850 kPa. Once the pressure has dropped below 850 kPa, the valve will close. This condition is normal and does not indicate a defective relief valve.

WARNING! Do not plug, cap or reduce the outlet pressure and temperature valve.

The pressure-relief device is to be operated regularly to remove lime deposits and to verify that it is not blocked.

DANGER! Failure to operate the relief valve easing gear at least once every six months may result in the water heater exploding. Continuous leakage of water from the valve may indicate a problem with the water heater.

WATER WEEPING OR DRIPPING FROM PRESSURE RELIEF VALVE

You may experience water weeping or dripping from your water heater's Pressure and Temperature (P & T) Relief Valve when your water heater is operating. Water weeping or dripping from the P & T Valve does not always mean the P & T Valve is defective. As water is heated, it expands. The water system in a recreational vehicle is a closed system and does not allow for the expansion of heated water. When the pressure of the water system exceeds the relieving point of the P & T Valve, the valve will relieve the excess pressure. Suburban recommends that a check valve not be installed directly at the inlet to the water heater tank. This will increase weeping of the pressure relief valve.

One way to reduce the frequency of this occurrence is to maintain an air pocket at the top of the water heater tank. This air pocket will form in the tank by design. However, it will be reduced over time by the everyday use of your water heater. To replenish this air pocket:

1. Turn off water heater.
2. Turn off cold water supply line.
3. Open a tap in the RV.
4. Pull out on the handle of the Pressure Relief (P & T) Valve and allow water to flow from the valve until it stops.
5. Release handle on P & T Valve - it should snap closed.
6. Close tap and turn on cold water supply; as the tank fills, the air pocket will develop. Repeat this procedure as often as needed to reduce the frequency of the weeping of the P & T Valve. If the weeping persists after following this procedure, you may elect to install an expansion or accumulator tank in the cold water line to relieve the pressure caused by thermal expansion.

Suitable fittings are required to be installed in the pressure relief valve for piping the water away. A hole for the discharge pipe must be drilled in the bottom of the control housing and the piping passed through the hole. The hole through which the piping passes must be sealed water tight.

The discharge pipe must not be reduced in size along its length. The length and number of bends should be kept to a minimum and should be supported in a manner to reduce the risk of crushing or blockage.

Please contact your local dealer for assistance.

DRAINING AND STORAGE INSTRUCTIONS

If unit is to be stored during the winter months, the heater must be drained to prevent damage in the case of freezing temperatures.

1. Turn off gas supply to the water heater.
2. Turn off pressure pump on the water system.
3. Open both hot and cold water taps.
4. Open the drain on the water heater. (Remove anode rod)
5. Follow RV manufacturer's instructions for draining of the entire water system.

NOTE: Be certain to refill water heater with water before re-lighting the appliance.

ODOR FROM HOT WATER SYSTEM

Odor from the hot water system is not a service problem and many water supplies contain sufficient amounts of sulphur to produce an odor. The odor is similar to rotten eggs and is often referred to as "sulphur water". It is not harmful - only unpleasant to smell. Sulphur water can be caused by a chemical action or by bacteria. The solution to eliminate is chlorination of the water system. Add about 17.75 cL of chlorinated common household liquid bleach to each 38 Liters in the

water tank. Then run the chlorinated water throughout the system, opening each faucet one at a time until you smell the chlorine. Let the RV sit for a few days and the chlorine should take care of the problem. Then you will need to take care of the chlorine. Remove the chlorine by flushing the system with fresh water. This may take several attempts. You may consider adding a filtering system that removes chlorine and prevents sulphur water. If the sulphur or rotten egg smell continues, flush the system once again as described above and replace anode rod as necessary.

REMOVING WATER HEATER

1. Shut off gas supply and disconnect gas supply line from water heater.
2. Shut off water supply. Drain water from tank following instructions under "Draining and Storage".
3. Disconnect hot and cold water lines from water heater.
4. Remove screws or nails securing control housing to framed opening.
5. Slide heater out. To reinstall, follow instructions in manual under "Installation Instructions".

WINTERIZING

If your water heater plumbing system is equipped with a bypass kit, use it to close off the water heater, drain the water heater completely and leave the water heater closed off (out of the system) in the bypass position *particularly* if you are introducing antifreeze into the plumbing system. Antifreeze can be very corrosive to the anode rod creating premature failure and heavy sediment in the tank. If the plumbing system is not equipped with a bypass kit, and you intend to winterize by adding antifreeze to the system, remove the anode rod (storing it for the winter) and replace it with a 19mm drain plug.

HIGH ALTITUDE DERATING

Suburban's water heaters are certified by nationally recognized testing laboratories for operation without modifications at altitudes up to 4,500 feet. Operation above this elevation may require derating by 4 percent for every 1,000 feet above sea level. As an example, at 8,000 feet, the water heater should be derated approximately 32 percent.

If the unit is not properly derated, lack of sufficient oxygen for combustion may produce improper burner operation. Pilot outage caused by burner lift-off or sooting from a yellow burner may occur indicating the possibility of carbon monoxide. You may also notice a lack of efficiency in heating the water because of incomplete combustion of the burner at these higher altitudes.

Consult with the local gas company, your dealer, an RV service agency or Suburban Manufacturing Company for proper derating of the unit. Change-out of the orifice (derating) should be done by the dealer or an authorised service agency.

NOTE: It is important that once the unit has returned to lower elevation (below 4,500 feet) this high altitude derating and pilot adjustments (if equipped) be reversed for proper operation of the unit.

OPERATING INSTRUCTIONS

WARNING! If you do not follow these instructions exactly, a fire or explosion may result causing property damage, personal injury or loss of life.

WARNING! Before operating water heater, be sure tank is filled with water. See "Safety Warnings".

- A. This appliance does not have a pilot. It is equipped with an ignition device which automatically lights the burner. Do not try to light the burner by hand.
- B. BEFORE LIGHTING smell all around the appliance area for gas. Be sure to smell next to the floor because some gas is heavier than air and will settle on the floor.

WHAT TO DO IF YOU SMELL GAS

- Do not try to light any appliance.
 - Do not touch any electric switch.
 - Do not use any phone in your building.
 - Immediately call your gas supplier from a neighbor's phone. Follow the gas supplier's instructions.
 - If you cannot reach your gas supplier, call the fire department.
- C. This is an automatic gas valve, no adjustments are necessary. Do not attempt to repair the gas valve. This may result in a fire or explosion.
 - D. Do not use this appliance if any part has been under water. Immediately call an authorised service technician to inspect the appliance and to replace any part of the control system and any gas control which has been under water.
 - E. Before operating water heater, check the location of the vent to make sure it will not be blocked by the opening of any door on the trailer. If it can be blocked, do not operate the water heater with the door open.

OPERATING INSTRUCTIONS

1. STOP! Read the safety information provided.
 2. Turn off all electric power to the appliance.
 3. Turn "OFF" gas supply.
 4. Wait five minutes for gas to clear the area. If you smell gas then STOP! Follow instructions in item B of the safety information. If you don't smell gas, go to next step.
 5. Turn "ON" gas supply.
 6. Turn on 12 volt electrical power to the appliance.
 7. Turn switch to "ON" position. If the burner does not light, the system will automatically attempt two more tries for ignition before lockout. See Figure 8A.
- NOTE:** Each ignition cycle will have a 15 second purge before spark cycle if system is a three try system.

8. If lockout occurs before main burner lights, turn switch to "OFF", wait five seconds and turn switch to "ON" position. This will restart the ignition cycle. The first start-up of the heater may require several ignition cycles before all air is purged from the gas lines.
- If the burner will not come on, the following items should be checked before calling a service person.
1. Switch turned off.
 2. Gas supply to heater is empty or turned off.
 3. Reset button on ECO is tripped

OPERATING INSTRUCTIONS FOR UNITS WITH ELECTRIC ELEMENT

Electric water heaters are designed to operate with a minimum amount of service problems; however, proper operation and care is essential.

By far the most common trouble with electric water heaters results from energizing the water heater before it is filled with water. Even brief operation of the electric element without water in the tank will burn-out the electric heating element.

Turn off gas supply to the water heater. To energize the electric heating element, turn the switch to "ON." Reverse the procedure to disconnect electric heating element.

The switch is located behind the water heater door in the lower left corner of the control housing. The water temperature will be regulated by the thermostat.

This procedure is necessary so as to prevent 240 V element and gas heating from operating simultaneously.

TO TURN OFF WATER HEATER

1. Turn switch to "OFF" position.
2. Turn off electrical power to the appliance.
3. Turn off gas supply.
4. If vehicle is to be stored or heater is going to be turned off while subject to freezing temperature, drain water heater. (See "Draining and Storage Instructions.")

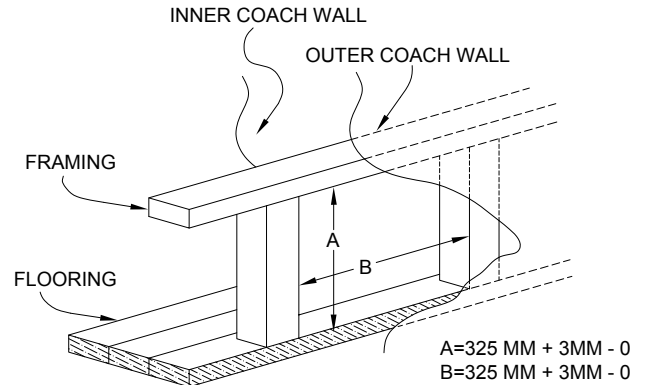

Figure 1

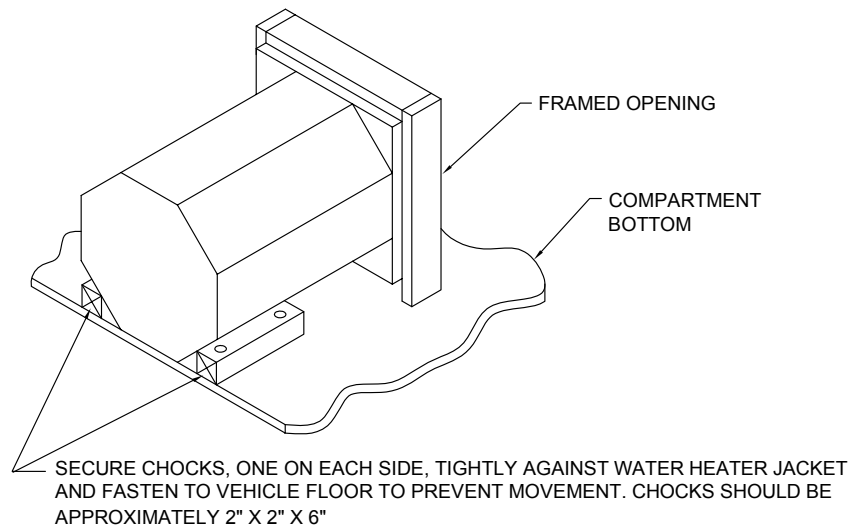

Figure 1A

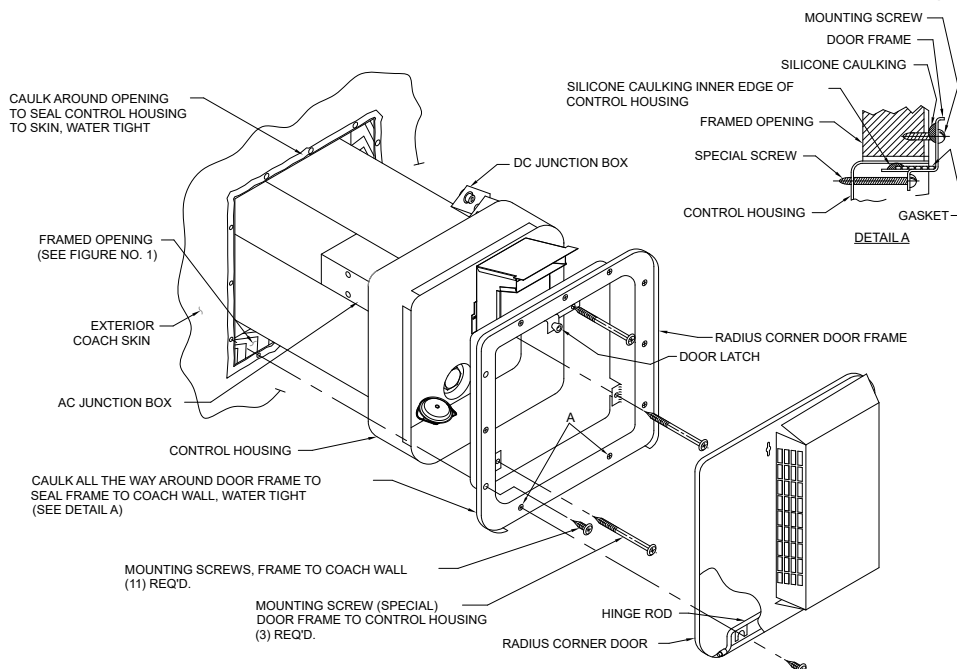

Figure 2
(Models SW4DEA and SW6DEA)

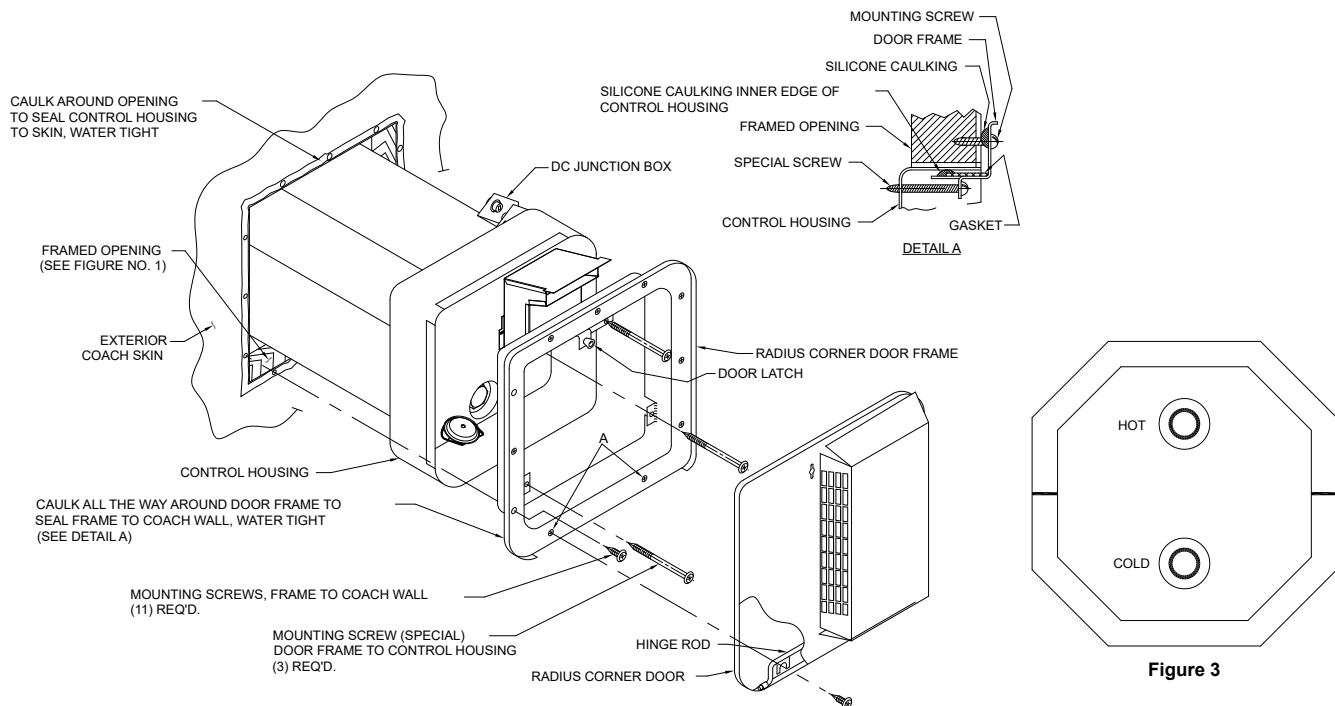

Figure 2A
(Models SW4DA and SW6DA)

RADIUS CORNER DOOR INSTALLATION
SW4DEA, SW6DEA WATER HEATERS
JW 3/11/11 A-204649-A

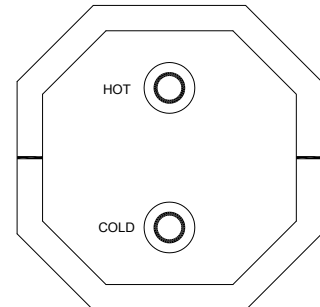

Figure 3

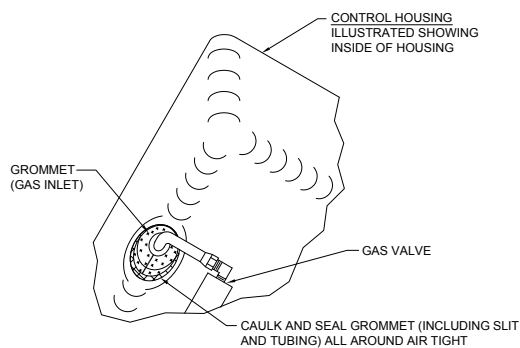

Figure 4

240 V.A.C. ONLY

DISCONNECT POWER SUPPLY BEFORE REMOVING COVER

SUBURBAN MANUFACTURING COMPANY, DAYTON, TENNESSEE

CODE	COLOR
BK	BLACK
W	WHITE
G	GREEN

240 V.A.C. - SINGLE PHASE - 1440 WATT ELEMENT - 50 CYCLE
TOTAL CONNECTED WATTS = 1440 - AMPS = 6
MAX. WORKING PRESSURE 850 KPA

IF ANY OF THE ORIGINAL WIRE AS SUPPLIED WITH THE HEATER MUST BE REPLACED, IT MUST BE REPLACED WITH 14GA. 105°C WIRE OR ITS EQUIVALENT. INDOOR USE ONLY APP. NO. Q00145

Figure 5A

12 V.D.C. ONLY

IF ANY OF THE ORIGINAL WIRE AS SUPPLIED WITH THE WATER HEATER MUST BE REPLACED, IT MUST BE REPLACED WITH 18 GA., 105°C WIRE OR IT'S EQUIVALENT.

BR	BROWN
Y	YELLOW
G	GREEN
BL	BLUE
R	RED
BK	BLACK

DISCONNECT POWER SUPPLY BEFORE SERVICING THERMOSTAT AND HI-LIMIT UNDER ACCESS COVER.

CAUTION: DO NOT HI-POT (DIELECTIC HIGH VOLTAGE TEST) THIS UNIT AFTER INSTALLATION. TO DO SO MAY CAUSE COMPONENT DAMAGE AND VOIDS WARRANTY OF WATER HEATER.

340461

Figure 5

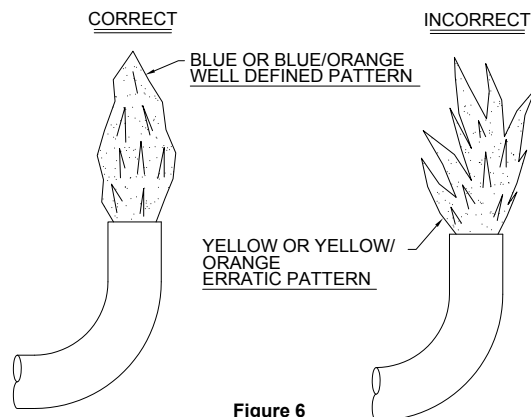
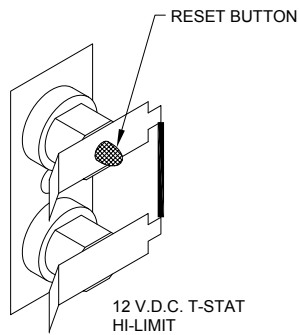
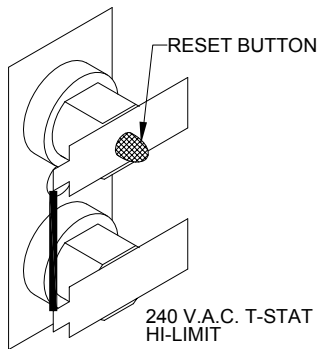

Figure 6



12 V.D.C. T-STAT
HI-LIMIT
Figure 7
(All Models)



240 V.A.C. T-STAT
HI-LIMIT
Figure 7A
(Models SW4DEA and SW6DEA)

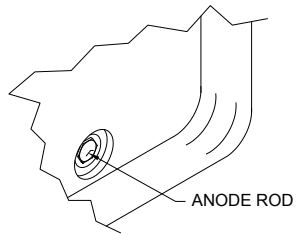

Figure 8

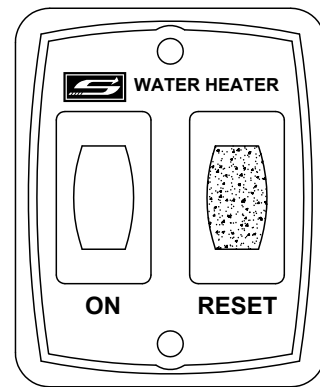

Figure 8A

FOR YOUR SAFETY READ BEFORE OPERATING

WARNING! If the user of this appliance fails to maintain it in the condition in which it was shipped from the factory or if the appliance is not used solely for its intended purpose or if appliance is not maintained in accordance with the instructions in this manual, then the risk of a fire and/or the production of carbon monoxide exists which can cause personal injury, property damage or loss of life.

TROUBLE SHOOTING GUIDE

This can be used as a guide that will enable you to solve most of the problems that the customer could have with the heater.

IF AFTER CHECKING THE CHART AND THE UNIT WILL STILL NOT PERFORM - TURN THE APPLIANCE OFF AND CONTACT THE AUTHORISED SERVICE PROVIDER.

SOOTING	WILL NOT COME ON	NOT ENOUGH HOT WATER	WATER TOO HOT	POSSIBLE CAUSE
	XXXXX			Possible malfunction of the bottled gas regulator
		XXXXX		Main burner orifice too small or clogged.
			XXXXX	Check thermostat position. Be sure it is properly mounted.
XXXXX				Thermostat not shutting off completely.
XXXXX				Yellow flame due to improper air shutter adjustment.
XXXXX				Lint or dirt in burner tube.
XXXXX				Leaves or other obstructions in flue box.

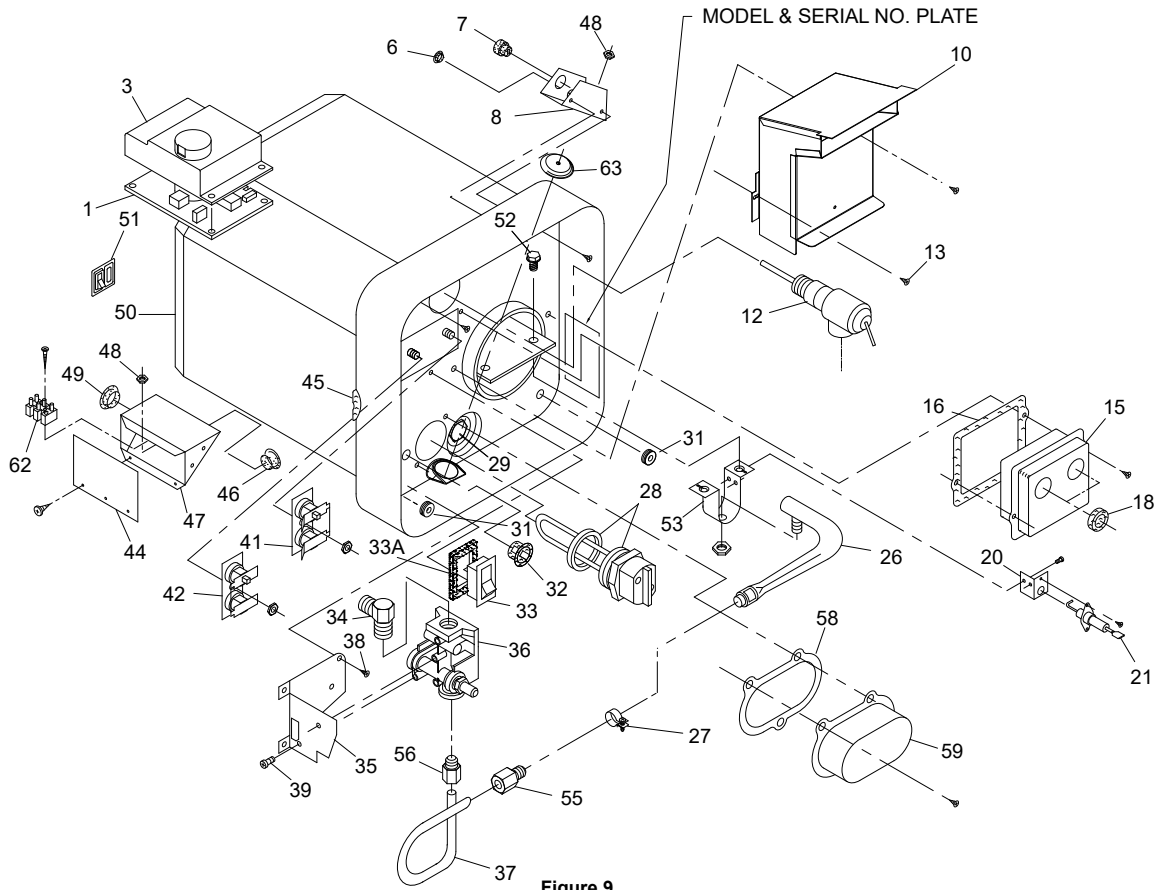

Figure 9
SW4DEA AND SW6DEA

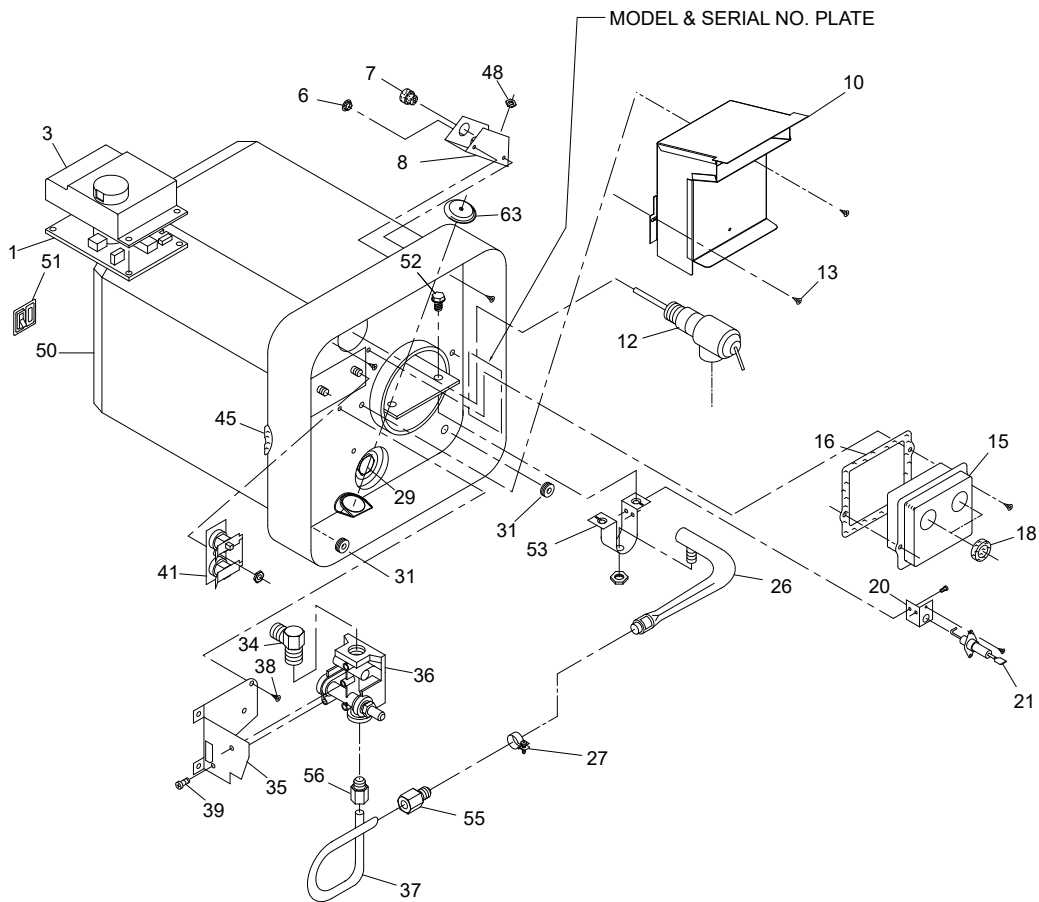

Figure 9A
SW4DA AND SW6DA

PARTS ILLUSTRATION AND REPLACEMENT PARTS LIST

PARTS LIST FOR MODELS: SW4DA • SW6DA • SW4DEA • SW6DEA

**Only factory authorized parts are to be used.
Do not attempt to repair defective parts.**

When ordering repair parts from your dealer or a distributor, always give the following information:

1. Part Number (Not Item No.)
2. Part Description
3. Model No. and Serial No. of your Heater
4. Number of Parts Required

ITEM NO.	DESCRIPTION	PART NUMBER
1	Module Board	521114
3	Cover, Module Board	090613
6	Bushing, Snap 1/2"	070270
7	Bushing, Strain Relief 5/8"	230216
8	D.C. Junction Box Assembly	090517
10	Flue Collector Assembly Complete	102434
12	Valve, Pressure Relief (SW4DEA, SW6DEA)	161166
	Valve, Pressure Relief (SW4DA, SW6DA)	
13	Screw #10 x 1/4	121577
15	Cover, Thermostat/Hi-Limit	090562
16	Gasket, Thermostat Cover	070987
18	Grommet	070874
20	Bracket, Electrode Mounting	063187
21	Electrode	232258
26	Burner Assembly with orifice	010844
27	Air Shutter Assembly (Main Burner)	010857
28	Electric Element with Gasket (Only for SW4DEA, SW6DEA)	520831
29	Anode	232767
31	Grommet	071246
32	Bushing, Snap 1/2" (Only for SW4DEA, SW6DEA)	070270
33	Switch, Electric Element (Only for SW4DEA, SW6DEA)	233110
33A	Gasket, Switch (Only for SW4DEA, SW6DEA)	071016
34	Gas Fitting	170374
35	Bracket, Valve Mounting	063243
36	Valve, Gas (LP)	161164

ITEM NO.	DESCRIPTION	PART NUMBER	
37	Manifold, Outlet	171420	
38	Screw #10 x 1/4 (4 Required)	121577	
39	Screw #8-32 x 3/8 Type F (2 Required)	121934	
41	Switch Assembly, 12 V.D.C. T-Stat/Hi-Limit (All Models)	232319	
42	Switch Assembly, 220 V.A.C. T-Stat/Hi Limit (Only for SW4DEA, SW6DEA)	232317	
44	Cover, Junction Box (Only for SW4DEA, SW6DEA)	090576	
45	Grommet, Gas Inlet	070989	
46	Bushing, Snap 7/8" (Only for SW4DEA, SW6DEA)	230218	
47	A.C. Junction Box Assembly (Only for SW4DEA, SW6DEA)	090575	
48	Nut, 10-24 Keps (Green)	121576	
49	Bushing, Snap 7/8" (Only for SW4DEA, SW6DEA)	230218	
50	Foam Jacket (SW6DEA, SW6DA)	520868	
	Foam Jacket SW4DEA, SW4DA)	520867	
51	Switch, Lamp and Plate Assembly	232589	
52	Screw 8mm - 4.0 x 1/2 Hex Washer Head (2 Required)	121943	
53	Burner Bracket	063444	
55	1/4 Loxit Nut (Manifold to Burner)	171463	
56	1/4 Loxit Nut (Manifold to Valve)	171463	
57	Electrode Wire (Not Shown)	232456	
58	Gasket, Element Cover (Only for SW4DEA, SW6DEA)	070988	
59	Cover, Element (Only for SW4DEA, SW6DEA)	090445	
61	Door, Radius Corner "PW" (Not Shown)	Arctic White	6270AAW
		Black	6270AEB
		Polar White	6270APW
62	Terminal Block (Only for SW4DEA, SW6DEA)	232669	
63	Plug, Break through	233309	

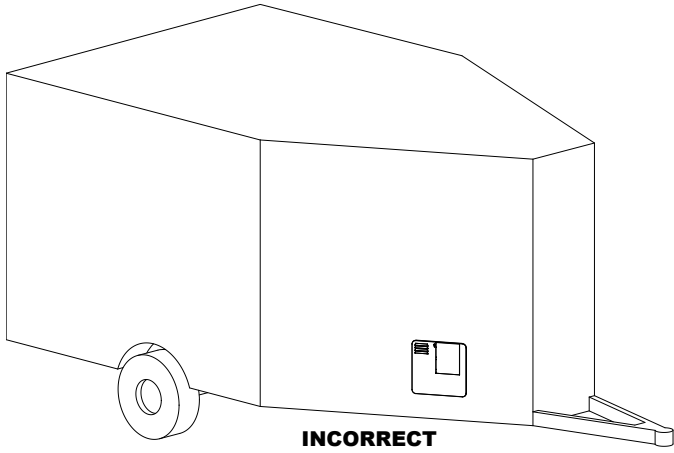

INCORRECT

Figure 10

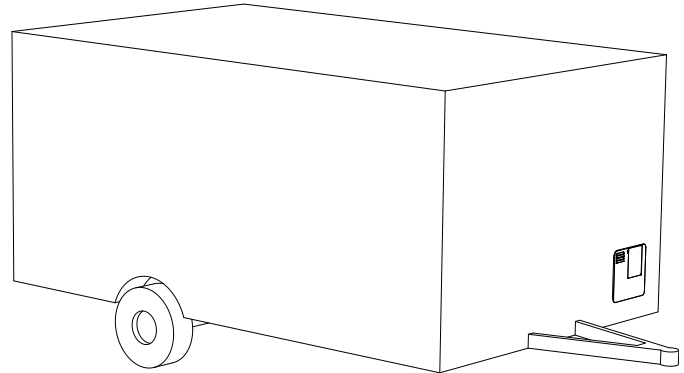

INCORRECT

Figure 11

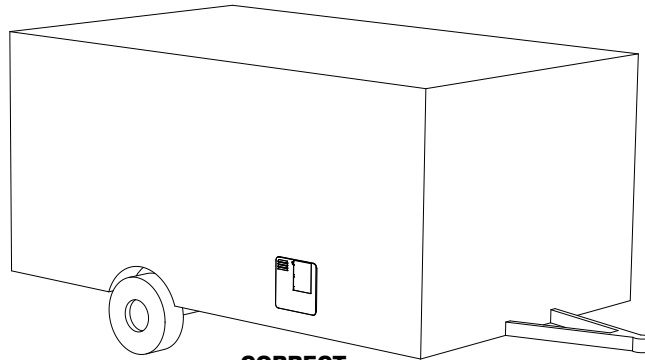

CORRECT

Figure 12

RECREATIONAL VEHICLE WATER HEATER LIMITED WARRANTY

THIS IS A LIMITED 24 MONTH WARRANTY ONLY!!

This water heating product is warranted by Coast to Coast RV Services to the original purchaser to be free from defects in material and workmanship under normal use and maintenance for a period of 24 months from the date of purchase, regardless of the commencement date of use. It is the responsibility of the consumer/owner to establish the warranty period. Coast to Coast RV Services does not use warranty registration cards for its standard warranty. You are required to furnish proof of purchase date through a bill of sale or other payment record.

Coast to Coast RV Services will replace any parts that are found to be defective within the first 24 months and will pay a warranty service allowance directly to the authorized Coast to Coast RV Services approved Agent at rates mutually agreed upon between Coast to Coast RV Services and its authorized service center or agent. Water heater must be returned to a Coast to Coast RV Services authorized service center. Coast to Coast RV Services will not bear costs involving traveling time from their service agents.

Service agents can perform warranty repairs on site but all traveling time will be paid by owner of Vehicle or Caravan.

COAST TO COAST RV SERVICES WILL NOT BE RESPONSIBLE FOR:

1. Normal maintenance as outlined in the installation and operation instructions owner's manual including cleaning of the component parts and cleaning or replacement of the burner orifice. Any water damage arising directly or indirectly from any defect in the water heater or component parts or from its use.
2. Initial check outs and subsequent check outs which indicates the water heater is operating properly or diagnosis without repair.
3. Damage or repairs required as a consequence of faulty or incorrect installation or application not in conformance with installation instructions.
4. Failure to start or operate due to loose or disconnected wire, water or dirt in controls, fuel lines and gas tanks, improper gas pressure or low voltage.
5. Cleaning adjustment of components, electrode, burner tube, pilot and thermocouple.
6. Costs incurred in gaining access to the water heater.
7. Parts or accessories not supplied by Coast to Coast RV Services.
8. Freight charges incurred from parts replacement.
9. Damage or repairs as a consequence of any misapplication, abuse, unreasonable use, unauthorized alteration, improper service, improper operation or failure to provide reasonable and necessary maintenance.
10. Any products whose serial number has been altered, defaced or removed.
11. Damage as a result of floods, winds, lightning, accidents, corrosive atmosphere or other conditions beyond the control of Coast to Coast RV Services.
12. Any special indirect or consequential property, economic or commercial damage of any nature whatsoever.

Some states do not allow the exclusion of accidental or consequential damages, so the above limitation may not apply to you.

NO REPRESENTATIVE, DEALER OR OTHER PERSON IS AUTHORIZED TO ASSUME FOR COAST TO COAST RV SERVICES ANY ADDITIONAL, DIFFERENT OR OTHER LIABILITY IN CONNECTION WITH THE SALE OF THIS WATER HEATING PRODUCT.

For full warranty terms and conditions, please visit www.coastrv.com.au or www.coastrv.co.nz

This warranty gives you specific legal rights. You may also have additional rights which vary from state to state.

IF YOU HAVE A PRODUCT PROBLEM

First:

If your RV has its original water heater and is still under the RV manufacturer's warranty. Follow the steps described in the RV owner's manual.

Second:

Contact: Coast to Coast RV Services
PO Box 6287
Silverwater NSW 1811 Australia
Phone: (02) 9645 7600
Fax: (02) 9645 7688
Email: warranty@coastrv.com.au